

Perfil 30x30

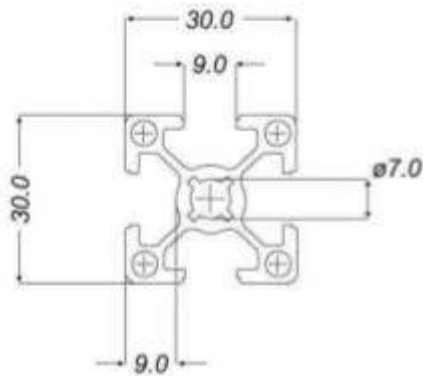

Massa (kg/m):	0.77
Comprimento:	6.0m ± 5mm
Área (cm ²):	2.91
Momento de inércia I _x (cm ⁴):	2.66
Momento de inércia I _y (cm ⁴):	2.66
Momento de resistência W _x (cm ³):	1.77
Momento de resistência W _y (cm ³):	1.77

Perfil 30x60

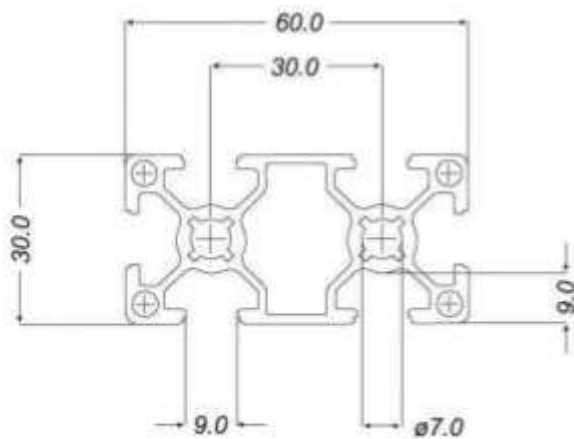

Massa (kg/m):	1.33
Comprimento:	6.0m ± 5mm
Área (cm ²):	5.03
Momento de inércia I _x (cm ⁴):	4.78
Momento de inércia I _y (cm ⁴):	18.40
Momento de resistência W _x (cm ³):	3.19
Momento de resistência W _y (cm ³):	6.13

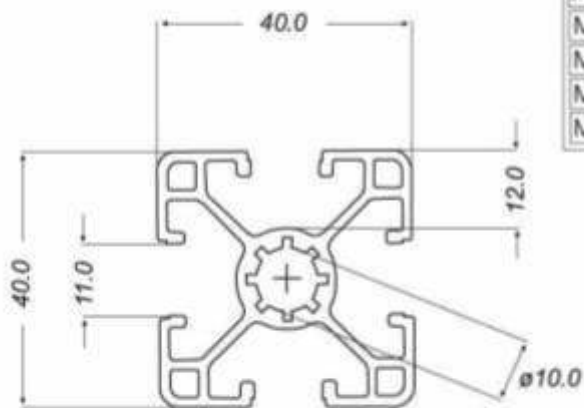
LINHA 40
Perfil 40x40

Massa (kg/m):	1.15
Comprimento:	6.0m \pm 5mm
Área (cm ²):	4.55
Momento de inércia I_x (cm ⁴):	11.21
Momento de inércia I_y (cm ⁴):	11.21
Momento de resistência W_x (cm ³):	4.99
Momento de resistência W_y (cm ³):	4.99

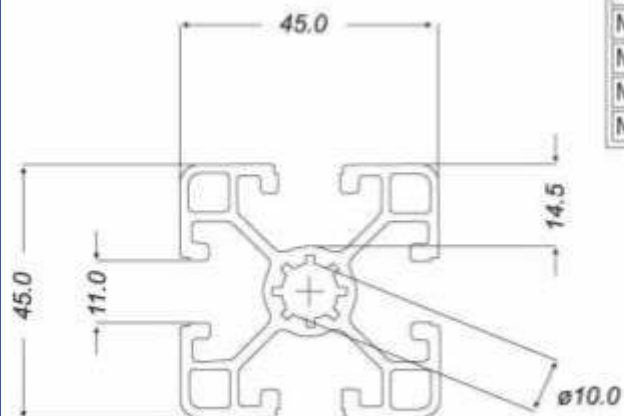
Perfil 45x45 Leve

Massa (kg/m):	1.50
Comprimento:	6.0m \pm 5mm
Área (cm ²):	5.69
Momento de inércia I_x (cm ⁴):	11.71
Momento de inércia I_y (cm ⁴):	11.71
Momento de resistência W_x (cm ³):	5.20
Momento de resistência W_y (cm ³):	5.20

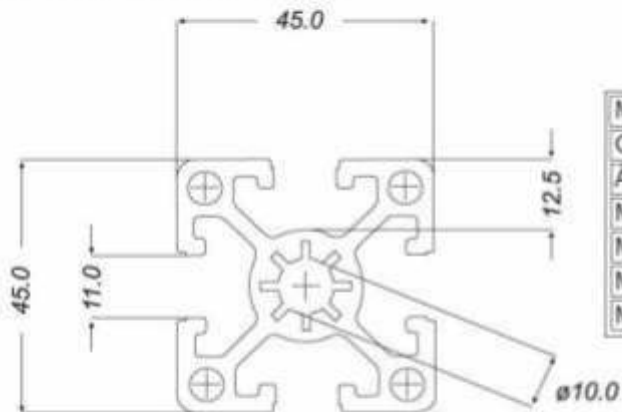
LINHA 45
Perfil 45x45 Pesado

Massa (kg/m):	2.09
Comprimento:	6.0m ± 5mm
Área (cm ²):	7.93
Momento de inércia I_x (cm ⁴):	15.67
Momento de inércia I_y (cm ⁴):	15.67
Momento de resistência W_x (cm ³):	6.96
Momento de resistência W_y (cm ³):	6.96

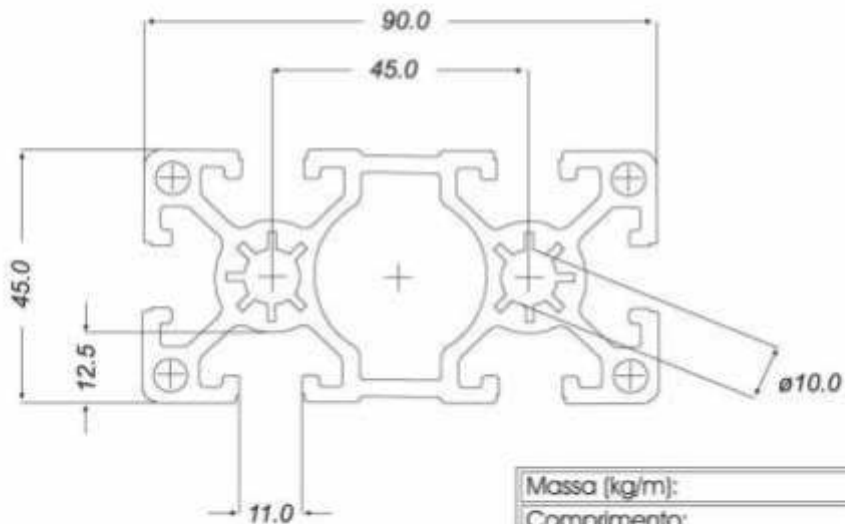
Perfil 45x90 Pesado

Massa (kg/m):	3.60
Comprimento:	6.0m ± 5mm
Área (cm ²):	13.64
Momento de inércia I_x (cm ⁴):	28.71
Momento de inércia I_y (cm ⁴):	111.00
Momento de resistência W_x (cm ³):	12.76
Momento de resistência W_y (cm ³):	24.67

LINHA TR

Trilho com roletes

Trilho com roletes com aba

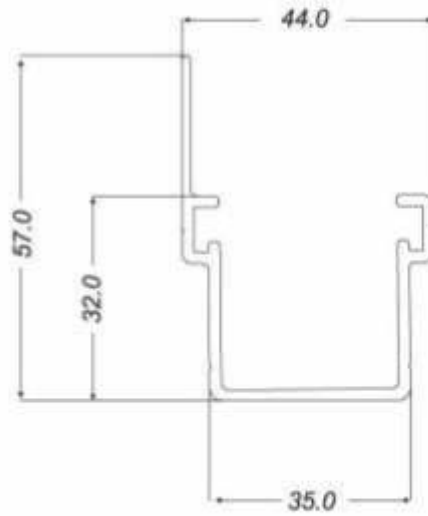
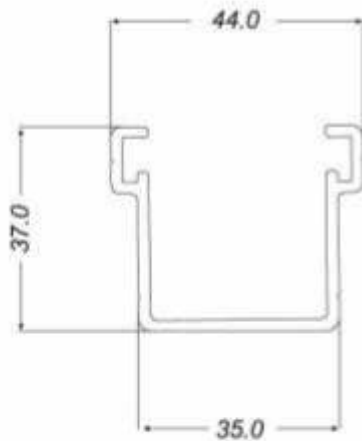

Capacidade:	45kg/m
Massa (kg/m):	0.51
Comprimento:	6.0m ±5mm

Capacidade:	45kg/m
Massa (kg/m):	0.65
Comprimento:	6.0m ±5mm

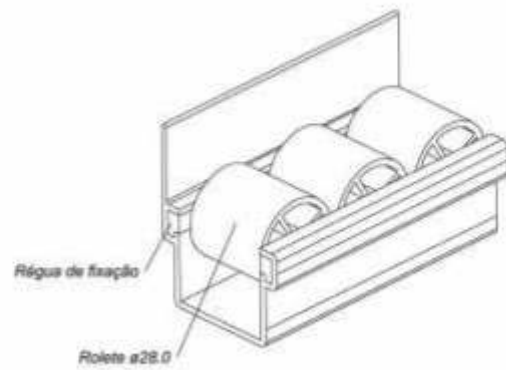
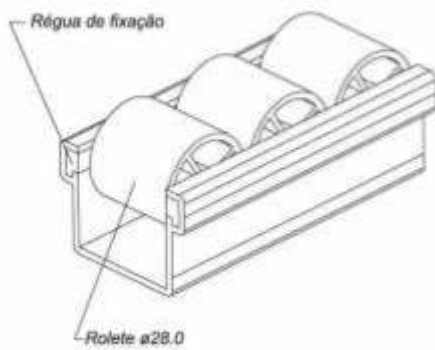

Porca "T" / Parafuso "T"

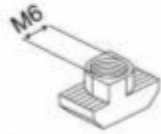

Porca "T" M6 p/ perfil 30

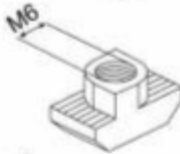

Porca "T" M6 p/ perfil 40/45

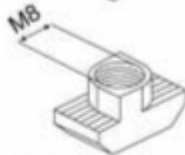

Porca "T" M8 p/ perfil 40/45

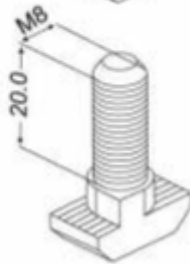

Parafuso "T" M8 p/ perfil 40/45



Parafuso p/ perfil 30

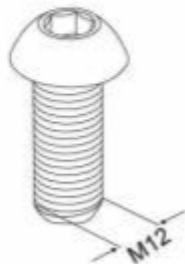

Parafuso p/ perfil 40/45

Acessórios

Pé fixo

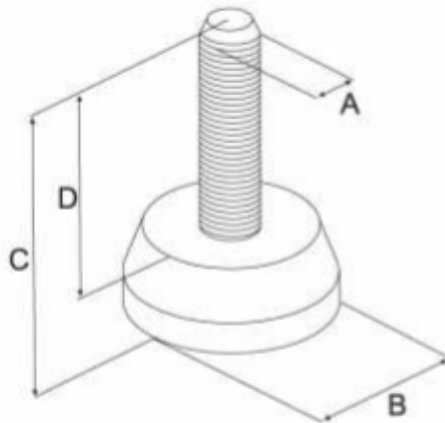

A	B	C	D
1/2"	ø40	70	55
M8	ø40	70	55
M12	ø40	65	47

Pé articulado

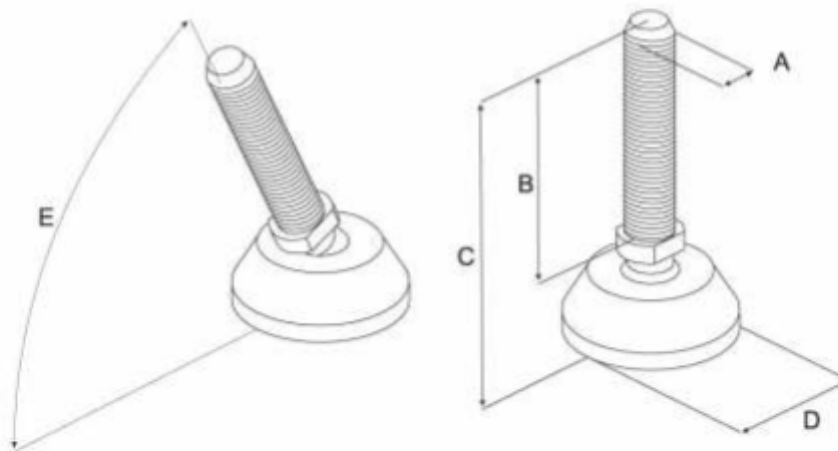

A	B	C	D	E
M8	48	77	ø42	65°
M12	65	113	ø42	65°
M12	85	113	ø60	65°

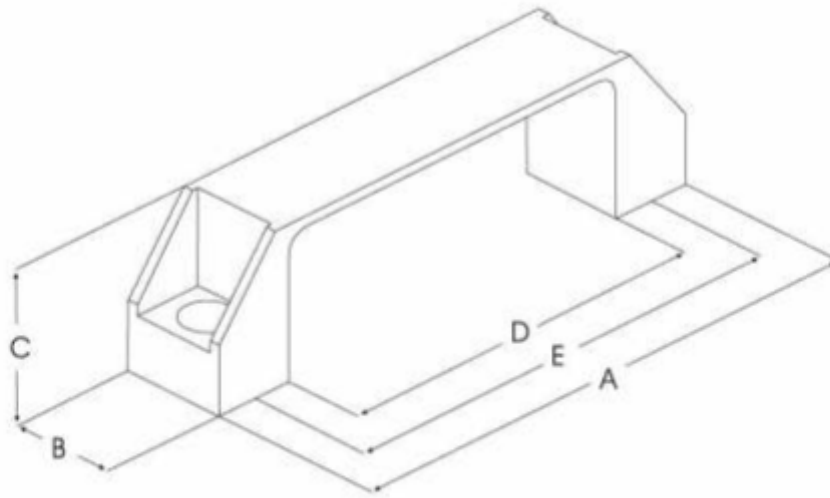

Puxador p/ Perfil 30 40 e 45					
A	B	C	D	E	Fixação
106.5	21	36	74	92	M6
133	26	41	94	115	M8
196	28.5	49	152	179	M8

Acessórios

Rodízio giratório c/ trava ø100

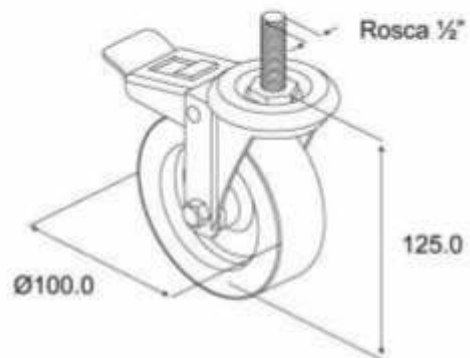

Rodízio giratório s/ trava ø100

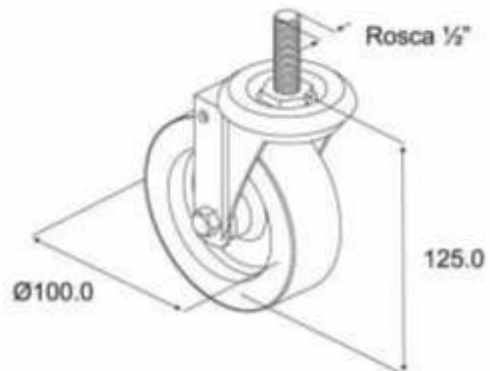

Rodízio fixo ø100

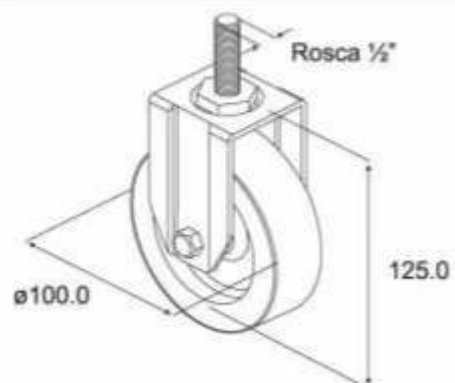

Acessórios

Rodízio giratório c/ trava ø75

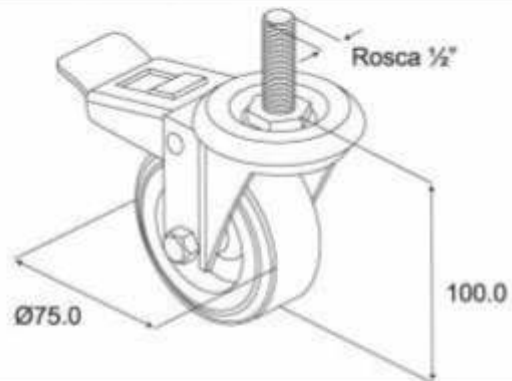

Rodízio giratório s/ trava ø75

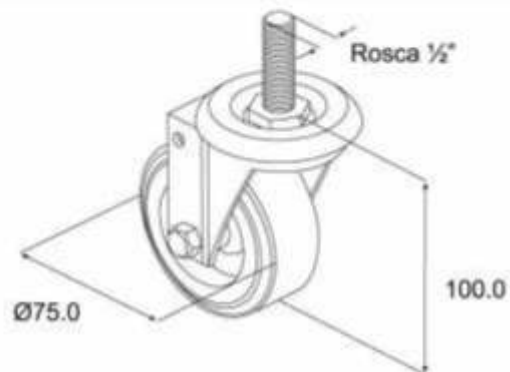

Rodízio fixo ø75

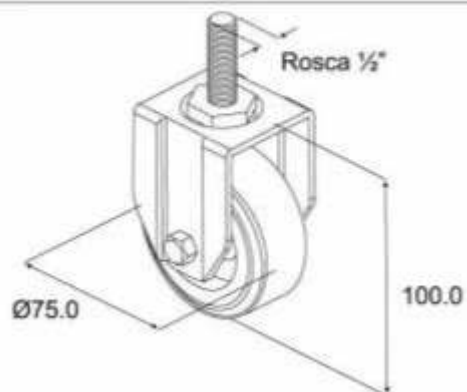

Acessórios

Cantoneira 40x40x24

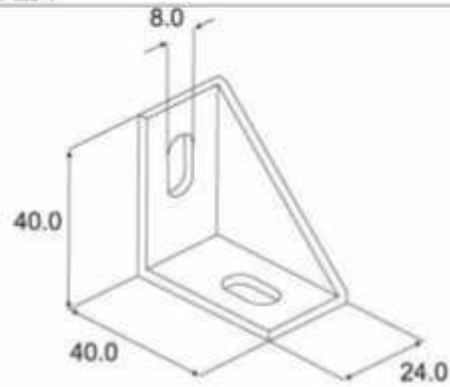

Cantoneira 40x40x40

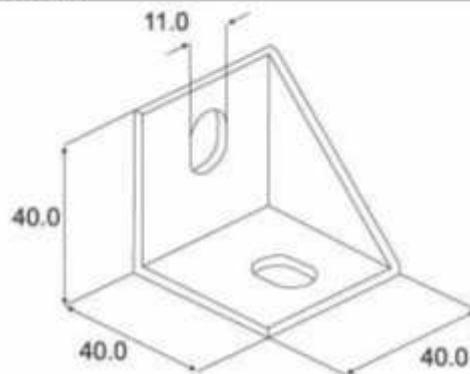

Cantoneira 80x80x40

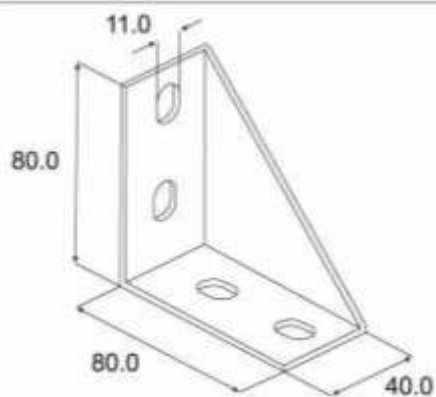

Acessórios

Esquadro de fundação

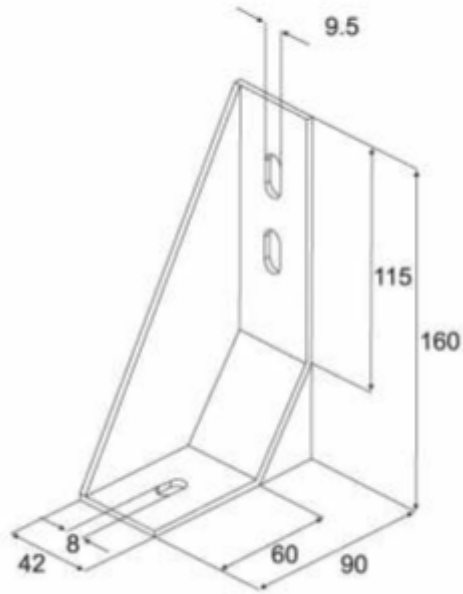

União de Perfil

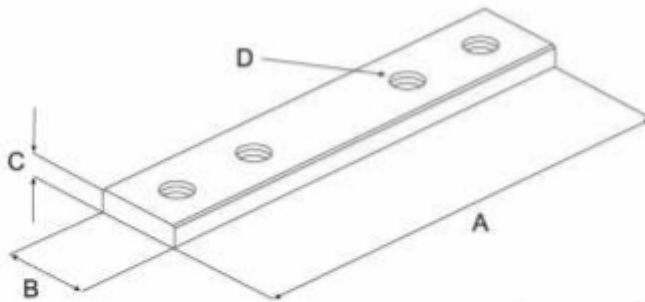

União de Perfil 30, 40 e 45				
A	B	C	D	Perfil
80	15	3	M6	30
100	19	5	M8	40/45

Suporte balancim

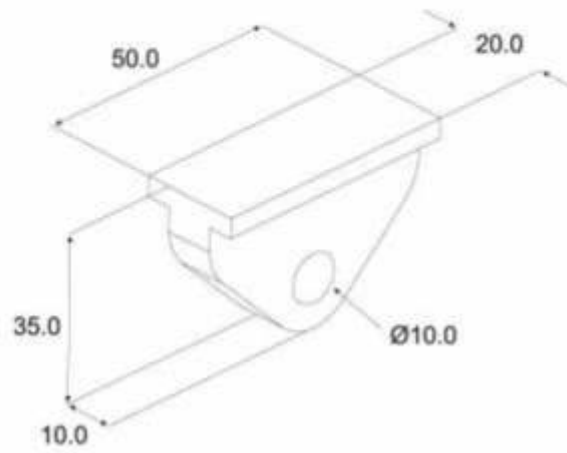

Acessórios

Dobradiça Perfil 30x30

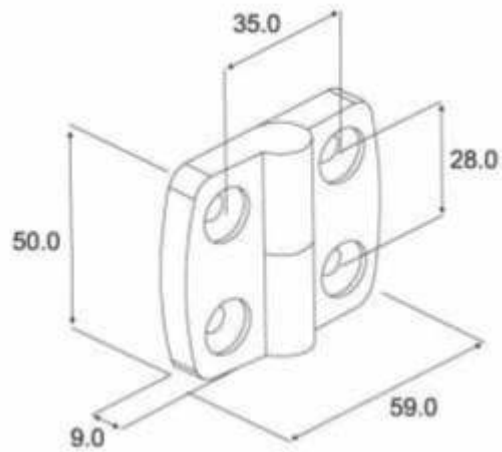

Dobradiça perfil 40x40

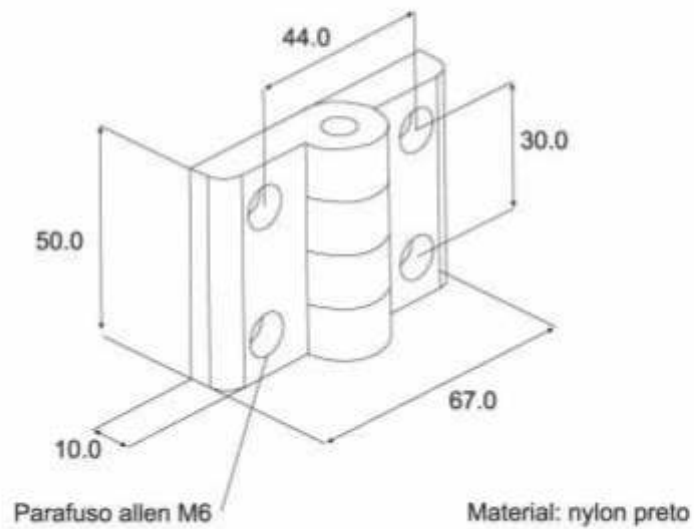

Acessórios

Tampa de acabamento



Tampa 30x30 p/ perfil 30

Tampa 40x40 p/ perfil 40

Tampa 45x45 p/ perfil 45

Perfil de acabamento PVC (40/45)



Perfil de acabamento esponjoso

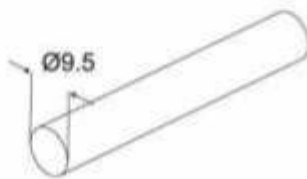

P/ perfil 30

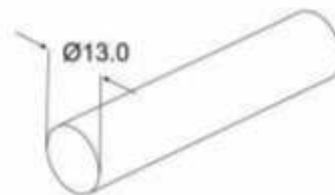

P/ perfil 40/45

